

IOT ENABLED SMART PARKING SYSTEM WITH EMBEDDED MICROCONTROLLER AND CLOUD ANALYTICS

Dr.S.Elango¹, K. Sandhiyavani², R. Santhiya³, K. Vanitha Sri⁴

¹Professor, Department of ECE, Arunai Engineering College (Autonomous), Tiruvannamalai, Tamil Nadu, India.
Email ID: elangosathappan@gmail.com

²Student, Department of ECE, Arunai Engineering College (Autonomous), Tiruvannamalai, Tamil Nadu, India.
Email ID: sandhiyavani6@gmail.com

³Student, Department of ECE, Arunai Engineering College (Autonomous), Tiruvannamalai, Tamil Nadu, India.
Email ID: santhiyaramesh210@gmail.com

⁴Student, Department of ECE, Arunai Engineering College (Autonomous), Tiruvannamalai, Tamil Nadu, India.
Email ID: k.vanithasri2005@gmail.com

Abstract—The rapid increase in the number of vehicles has made it difficult to find available parking spaces in urban areas. To address this issue, an Internet of Things (IoT) based smart parking system is proposed that integrates an embedded microcontroller with cloud-based monitoring. In this system, sensors are installed in parking slots to detect whether a space is occupied or free. The collected data is processed by a microcontroller and then transmitted to a cloud platform through Wi-Fi for real-time storage and monitoring. Users can access the parking status through a mobile or web interface, which helps them identify available spaces before entering the parking area. This reduces the time spent searching for parking and helps in minimizing traffic congestion. In addition, cloud-based analysis supports the study of parking usage patterns, enabling better management and planning. The proposed system provides a practical, efficient, and cost-effective solution for modern urban parking problem.

Keywords: Smart Parking System; Internet of Things (IoT); Parking Slot Detection; ESP32/Arduino; Cloud-Based Monitoring.

I. Introduction

Cities are having a hard time managing parking spaces because cities are growing quickly and more cars are on the road. A lot of traffic jams happen because drivers spend too much time looking for parking spots. This wastes gas, makes more carbon dioxide, and makes transportation less efficient. Most traditional parking systems use manual management or fixed allocation methods, which cannot keep up with the growing demand and lead to parking spaces being used poorly. The Internet of Things (IoT) has made it possible to create smart parking solutions that use connected sensors and built-in processing units. It is possible to make smart parking systems that are scalable and data-driven by using ultrasonic sensors, ESP32 microcontrollers, wireless communication, and cloud platforms like ThingSpeak. We present an IoT-based Smart Parking System in this paper. It uses ultrasonic sensors to detect cars without touching them, and an ESP32 microcontroller to handle local processing and Wi-Fi communication.

II. Existing work

At present, many urban parking systems still depend on basic or partially automated techniques. In these systems, parking space monitoring is primarily carried out using standard hardware components such as sensors, embedded microcontrollers, and local display units. Common sensors, including infrared (IR) and ultrasonic sensors, are used to detect whether a parking slot is occupied. The signals from these sensors are processed by an embedded microcontroller to determine the status of each parking space, which is then typically indicated using LEDs or local display panels within the parking area. Most of these existing systems focus solely on vehicle detection and offer limited monitoring capabilities. Their functionality is generally confined to local monitoring, lacking remote access for users.

Moreover, the collected parking data is usually not stored in centralised databases, preventing users from checking slot availability through mobile or web applications. Many of these systems also do not integrate with cloud services, perform real-time analytics, or leverage IoT connectivity.

Due to the absence of cloud storage and intelligent monitoring mechanisms, conventional parking systems are unable to analyse usage patterns or provide real-time information to drivers. This often makes it difficult for motorists to find available parking spaces, contributing to traffic congestion, higher fuel consumption, and inefficient use of parking resources. These limitations highlight the need for an advanced IoT-enabled smart parking system that incorporates cloud-based monitoring and real-time data management to enhance parking efficiency and user convenience.

III. Proposed Method

To overcome the limitations of traditional parking management systems, this study proposes an IoT-based Smart Parking System that combines embedded microcontroller technology with cloud-based data analytics. The primary goal of the system is to provide real-time monitoring of parking spaces, intelligent detection of slot availability, and remote access to parking information, thereby improving the efficiency of parking management in urban areas.

The system is built using key components, including parking slot sensors, an embedded microcontroller, a wireless communication module, a cloud database, and a user interface platform. Each parking space is equipped with sensors such as infrared (IR) or ultrasonic sensors that detect the presence or absence of vehicles. These sensors continuously monitor the parking slots and generate signals when a vehicle occupies or vacates a space.

The sensor signals are sent to the embedded microcontroller, which serves as the central processing unit of the system. The microcontroller processes the incoming data using logical algorithms to determine the occupancy status of each parking slot. Once processed, the updated information is transmitted to a cloud platform via a Wi-Fi module.

The cloud server plays a critical role in storing, organising, and analysing parking data. It ensures that real-time parking information is always up to date and accessible to users through a mobile application or web interface. This allows drivers to quickly identify available parking spaces before entering the parking area, reducing search time and traffic congestion.

In addition, the system leverages cloud analytics to examine parking usage trends, vehicle movement patterns, and overall demand. This data can help administrators optimise parking space utilisation and support efficient parking management in smart city environments.

By combining sensor technology, embedded systems, IoT communication, and cloud computing, the proposed smart parking system offers a scalable, intelligent, and efficient solution for the challenges of modern urban parking.

Components

(Hardware Components)

- **IR Sensor / Ultrasonic Sensor:** Detects whether a vehicle is present in each parking slot.
- **Microcontroller (ESP32 / Arduino):** Collects sensor data, processes the information, and controls the overall functioning of the parking system.
- **Wi-Fi Module:** Enables wireless communication between the microcontroller and the cloud server.
- **LED Indicator / Display:** Visually indicates the availability status of each parking space.
- **Power Supply:** Provides the necessary electrical power to operate all hardware components.

(Software Components)

- **Arduino IDE:** Platform used to write, edit, and upload program code to the microcontroller.
- **Embedded C / Arduino Programming:** Programming languages used to program and control the system.
- **Cloud Platform (Firebase / ThingSpeak):** Stores and manages parking data in real time while enabling remote monitoring.
- **Web or Mobile Interface:** Allows users to check real-time parking availability through web or mobile applications.

System Architecture

The proposed smart parking system is designed using an IoT-based architecture to monitor and manage parking space availability in real time. The system consists of sensors, a microcontroller, a wireless communication module, a cloud platform, and a user application.

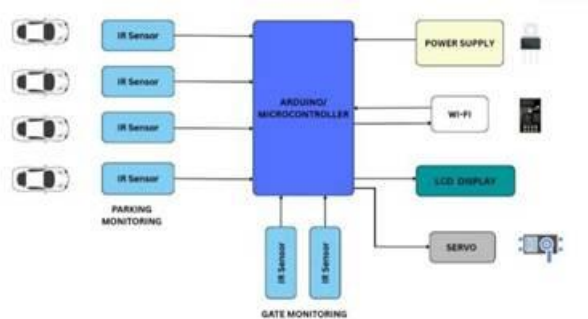

Fig 1: Block diagram

At the core of the system is the ESP32 microcontroller, which serves as the central controller by integrating vehicle detection, wireless communication, and cloud connectivity. Each parking slot is equipped with IR or ultrasonic sensors to detect the presence of vehicles. The sensor data is collected and processed by the ESP32, which then transmits the information via Wi-Fi to a cloud platform such as ThingSpeak or Firebase for storage and real-time monitoring. The parking status is made accessible to users through a mobile or web interface, enabling drivers to quickly identify free parking slots and reduce unnecessary vehicle circulation. A power management unit ensures that all sensors, the microcontroller, and communication modules operate reliably.

Overall, this system combines embedded processing, IoT communication, and cloud computing to deliver an intelligent, efficient, and real-time solution for urban parking management.

Prototype Model

The prototype model of the proposed smart parking system is developed to demonstrate the practical implementation of an IoT-based parking solution. It consists of an ESP32 microcontroller, parking slot sensors such as infrared (IR) or ultrasonic sensors, a power supply unit, and a wireless communication interface. In this setup, sensors are placed in each parking slot to detect the presence or absence of a vehicle. These sensors continuously monitor the parking spaces and send signals to the ESP32 microcontroller. The microcontroller processes the received data and determines the status of each parking slot based on predefined conditions. The processed information is transmitted to a cloud platform through the built-in Wi-Fi capability of the ESP32, where the data is stored and updated in real time. A mobile or web-based interface is used to display the parking availability, allowing users to check slot status easily. LED indicators may also be included in the prototype to visually represent whether a slot is occupied or free. The entire system is powered using a regulated power supply to ensure stable operation. This prototype model effectively demonstrates the integration of sensing, data processing, wireless communication, and cloud monitoring in a simple and scalable manner.

A. Vehicle Detection System

The vehicle detection system is responsible for identifying whether a parking slot is occupied or available. In the proposed smart parking system, infrared (IR) sensors and ultrasonic sensors are used to detect vehicles in real time. These sensors are installed in each parking slot and continuously monitor the parking area. Whenever a vehicle enters or leaves a slot, the sensors generate signals that are sent to the ESP32 microcontroller. The microcontroller processes this data and determines the occupancy status of each parking space.

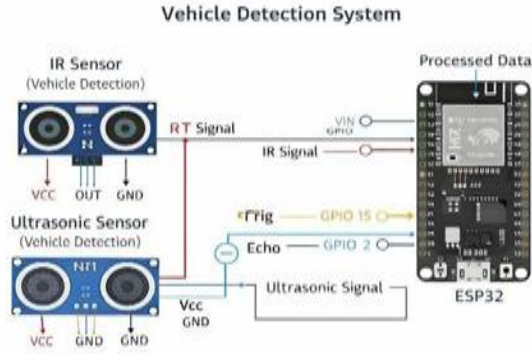

Fig 2: Circuit Diagram

For ultrasonic sensing, the distance between the sensor and the object (vehicle) is calculated based on the time taken for the ultrasonic signal to travel and return. The distance can be calculated using the following equation:

$$\text{Distance} = (\text{Time} \times \text{Speed of Sound}) / 2$$

The calculated distance is then compared with a predefined threshold value to determine the status of the parking slot. If the measured distance is less than the threshold value, the slot is considered occupied; otherwise, it is marked as available. This condition can be represented as:

$$\text{Slot Status} = \left\{ \begin{array}{l} \text{Occupied, if } d < d_{\text{threshold}} \\ \text{Available, if } d \geq d_{\text{threshold}} \end{array} \right\}$$

The ESP32 microcontroller updates the parking status based on this evaluation. This method ensures accurate and real-time vehicle detection, which improves the overall efficiency of the smart parking system.

B. Embedded Processing Unit

The embedded processing unit acts as the central control system of the smart parking architecture. In the proposed system, an ESP32 microcontroller is used to process sensor data and manage overall system operations. It receives input signals from parking sensors and analyzes the data to determine the status of each parking slot. Based on this processed information, the microcontroller controls communication with the cloud platform using its built-in Wi-Fi module.

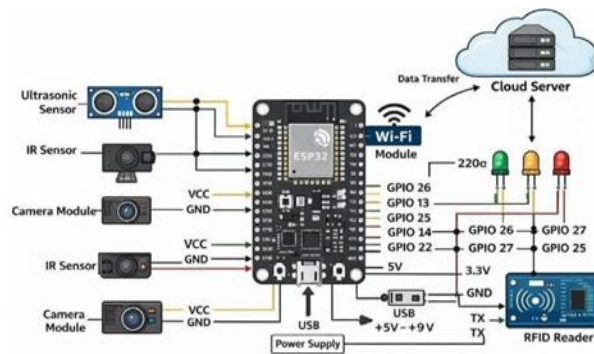

Fig. 3: Circuit Diagram

The decision-making process of the microcontroller is based on evaluating sensor inputs and converting them into parking status. This can be mathematically represented as:

$$S = f(d)$$

Where:

S = Slot status

d = Measured distance from sensor

The condition for determining slot status is defined as:

If $d < d_threshold$, then $S = Occupied$

If $d \geq d_threshold$, then $S = Available$

The ESP32 continuously processes sensor data using this logic and updates the parking status in real time. Its ability to handle data efficiently with low power consumption makes it suitable for IoT-based smart parking applications.

C. Wireless Communication System

The wireless communication system enables data transfer between the embedded processing unit and the cloud platform. In the proposed system, the ESP32 microcontroller uses its built-in Wi-Fi module to transmit parking data to the internet. This allows real-time monitoring of parking slot availability and provides remote access to parking information for users.

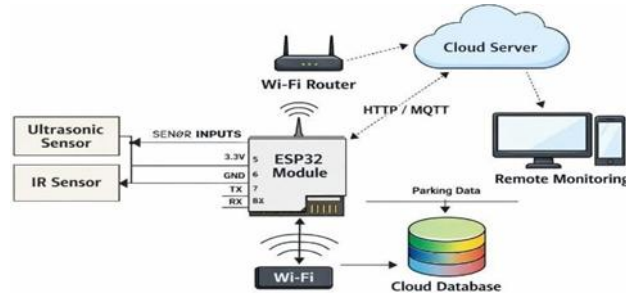

Fig 4: Circuit Diagram

The ESP32 collects processed data from the sensors and sends it to the cloud server using communication protocols such as HTTP or MQTT. The system ensures continuous data transmission so that the parking status remains updated. The efficiency of communication depends on the rate at which data is transmitted over the network.

The data transmission process can be expressed as:

$$R = D / T$$

Where:

R = Data transmission rate

D = Amount of data transmitted

T = Time taken for transmission

A higher transmission rate ensures faster updates of parking information in the cloud. The ESP32 maintains a stable Wi-Fi connection to ensure reliable communication between the hardware system and the cloud platform. This wireless communication plays an important role in enabling real-time updates and remote monitoring of the smart parking system.

D. Cloud-Based Data Management

The cloud-based data management system is responsible for storing, updating, and monitoring parking information collected from the embedded system. In the proposed smart parking system, cloud platforms such as ThingSpeak or Firebase are used to maintain a centralized database that stores the status of each parking slot. The ESP32 microcontroller sends real-time parking data to the cloud through Wi-Fi, where it is stored and made accessible for further processing and visualization.

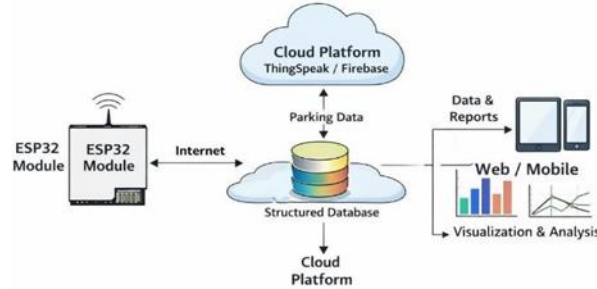

Fig 5: System Architecture

The cloud platform continuously updates the parking data and allows users or administrators to access the information through a mobile or web interface. This enables real-time monitoring of parking availability and supports analysis of parking usage patterns. The frequency at which the data is updated plays an important role in maintaining system accuracy.

The data update rate can be expressed as:

$$U = N / T$$

Where:

U = Data update rate

N = Number of updates

T = Time interval

In addition, the availability of parking slots can be calculated as:

$$\text{Available Slots} = \text{Total Slots} - \text{Occupied Slots}$$

These calculations help in maintaining accurate and up-to-date parking information. The cloud system also supports graphical visualization and data analysis, which improves parking space utilization and overall system efficiency.

E. Smart Parking Monitoring Interface

The smart parking monitoring interface provides a user-friendly platform for accessing real-time parking information. In the proposed system, a mobile or web-based application is used to display the availability of parking spaces. The interface retrieves data from the cloud platform and presents it in a simple and understandable format, allowing users to check parking status before entering the parking area.

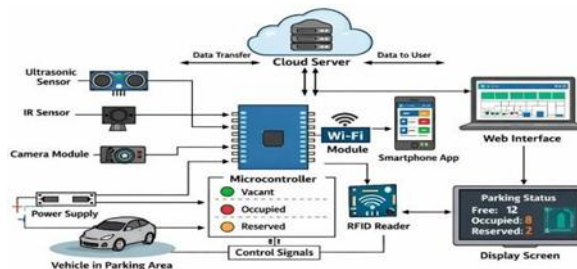

Fig 6: User Interface

The interface displays the status of each parking slot using indicators such as “occupied” or “available.” This helps drivers quickly identify free spaces, reducing the time spent searching for parking and minimizing traffic congestion. The system continuously updates the displayed information based on the data received from the cloud, ensuring accuracy and reliability.

The number of available parking slots can be calculated as:

$$\text{Available Slots} = \text{Total Slots} - \text{Occupied Slots}$$

The availability percentage can be expressed as:

$$\text{Availability (\%)} = (\text{Available Slots} / \text{Total Slots}) \times 100$$

These values can be displayed on the interface to provide better understanding of parking conditions. By offering real-time updates and clear visualization, the monitoring interface improves user convenience and supports efficient parking management.

F. Power Management System

The power management system ensures a stable and reliable supply of electrical energy to all components of the smart parking system. It provides the required power for sensors, the ESP32 microcontroller, and the communication modules. A regulated power supply unit is used to maintain constant voltage levels, which is essential for proper and continuous system operation.

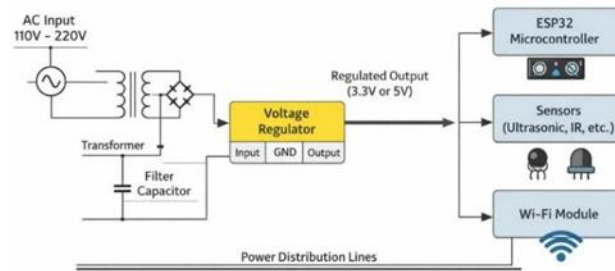

Fig 7: Circuit Diagram

In the proposed system, the input power is converted to suitable voltage levels using a voltage regulator. This regulated output is then distributed to all system components. Proper power management helps prevent fluctuations, reduces system errors, and ensures reliable performance of the smart parking system.

The total power consumption of the system can be calculated as:

$$P = V \times I$$

Where:

P = Power

V = Voltage

I = Current

Additionally, the total energy consumption over time can be expressed as:

$$E = P \times T$$

Where:

E = Energy

P = Power

T = Time

Efficient power management ensures continuous operation and improves the overall reliability of the system. It also supports scalability when the system is extended to larger parking environments.

Results

The proposed IoT-based Smart Parking System was successfully implemented and demonstrated using a working prototype model. The prototype consists of multiple parking slots, each equipped with infrared sensor modules for detecting vehicle presence. All sensors are connected to a central microcontroller unit, which processes the input signals and determines the real-time status of each parking slot. The system also includes indicator lamps assigned to each slot, providing a clear visual representation of whether a space is occupied or available.



Fig 8: Prototype Model

During testing, the prototype performed effectively under different conditions. The sensors responded accurately to the presence and absence of objects, and the microcontroller updated the slot status without noticeable delay. The communication module enabled smooth transmission of data, allowing the system to support real-time monitoring. The overall hardware setup, including the power supply and driver circuits, ensured stable and continuous operation.

The prototype model clearly demonstrates the integration of sensing, processing, and communication within a single system. It validates that the proposed approach can reduce the time required to find parking spaces, minimize manual effort, and improve overall parking management efficiency. The results confirm that the system is reliable, practical, and suitable for real-world smart parking applications.

Feature	Previous Methods	Proposed Smart Parking System
System Design	Standalone / manual systems	Integrated IoT-based parking system
Monitoring	Manual or local monitoring only	Real-time cloud-based monitoring
Slot Detection	Manual checking / basic sensors	IR sensor-based accurate detection
Data Storage	No storage or local storage	Cloud-based data storage
User Access	On-site information only	Remote access via web/mobile
Communication	No or limited communication	Wireless communication (Wi-Fi/GSM)
Response Time	Slow / delayed updates	Instant real-time updates
Automation Level	Low or partial automation	Fully automated system
Parking Guidance	Not available	Real-time slot availability display
System Efficiency	Low efficiency	High efficiency with smart control
Scalability	Limited expansion	Easily scalable system
User Convenience	Low	High with remote monitoring

Discussion

The proposed smart parking system operates effectively by combining sensor-based detection, embedded processing, and IoT communication. The infrared sensors accurately identify whether a parking slot is occupied or free, and the microcontroller processes this information to update the system status in real time. The use of visual indicators makes it easy to understand slot availability, while cloud connectivity enables remote monitoring. Overall, the system improves parking efficiency, reduces manual effort, and provides a convenient solution for managing parking spaces.

V. Conclusion

This paper presents the design and implementation of an IoT-based Smart Parking System using an ESP32 microcontroller, ultrasonic sensors, and cloud-based monitoring to enhance parking management efficiency. The system detects vehicle presence in parking slots through sensor-based detection, processes the data using the embedded controller, and transmits the information to a cloud platform via Wi-Fi for real-time monitoring. Experimental results show that the system provides accurate vehicle detection, reliable wireless communication, and efficient parking space management. By combining embedded systems, sensor networks, and IoT communication, the system reduces the time spent searching for parking and optimises space utilisation. The architecture is scalable, cost-effective, and suitable for deployment in smart cities, commercial complexes, educational campuses, and public parking areas. Cloud-based monitoring enables centralised access to parking data, supporting intelligent parking management. Future improvements may include mobile application integration, advanced data analytics, and automated parking guidance to further enhance user convenience and system performance.

VI. References

- [1] [1] A. Khanna and R. Anand, "IoT-based Smart Parking System," in *Proc. Int. Conf. Internet of Things and Applications (IOTA)*, 2016. Available: <https://ieeexplore.ieee.org/document/7562735/>
- [2] "Smart Parking System using IoT Technology," *IEEE Conf.*, 2019. Available: <https://ieeexplore.ieee.org/document/9077885/>
- [3] "IoT-Based Smart Parking System," *IEEE Conf.*, 2021. Available: <https://ieeexplore.ieee.org/document/10165132/>
- [4] T.-N. Pham *et al.*, "A Cloud-Based Smart-Parking System Based on Internet-of-Things Technologies," *IEEE Access*, 2015.
- [5] M. Ramasamy *et al.*, "IoT-Based Smart Parking System for Large Parking Lot," *IEEE ROMA*, 2018.
- [6] D. Vakula and Y. K. Kolli, "Low Cost Smart Parking System for Smart Cities," *ICISS*, 2017.
- [7] E. Redondi and M. Tagliasacchi, "A visual sensor network for parking lot occupancy detection in smart cities," *IEEE WF-IoT*, 2015.
- [8] "Smart Parking with Android App and IoT," *IEEE Conf.* (example IEEE implementation),
- [9] J. Immanuel *et al.*, "An Efficient IoT-Based Smart Vehicle Parking Management System," *IEEE ICCMC*, 2023, doi: 10.1109/ICCMC56507.2023.10083977.
- [10] A. O. Kotb and Y. Shen, "Smart Parking Guidance, Monitoring, and Reservations: A Review," *IEEE Intell. Transp. Syst. Mag*
